

Die genauen Masse der verschiedenen Pendellängen u.s.w. sind aus der Pendelliste zu entnehmen

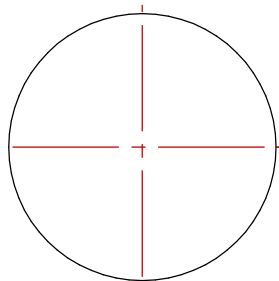

Hermle Werk
W0141-040

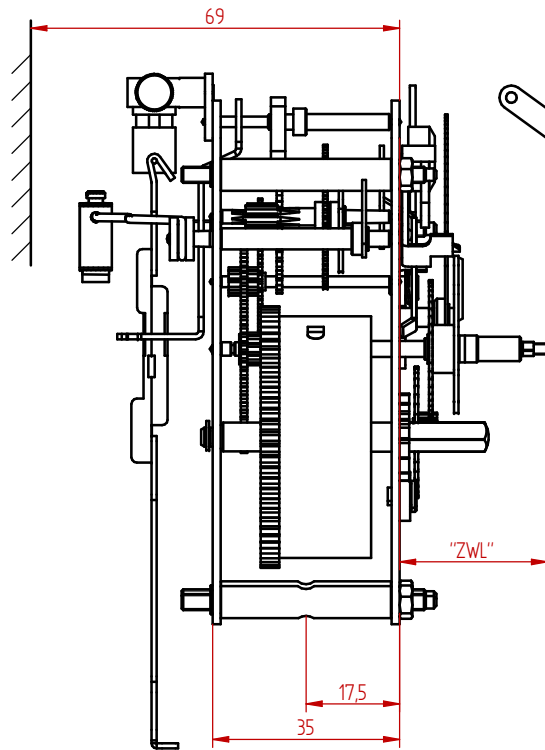

"ZWL" = Zeigerwerkslänge
length of centershaft

- W0141-040 = 33,1 mm
- W0141-043 = 53,1 mm
- W0141-041 = 27,6 mm

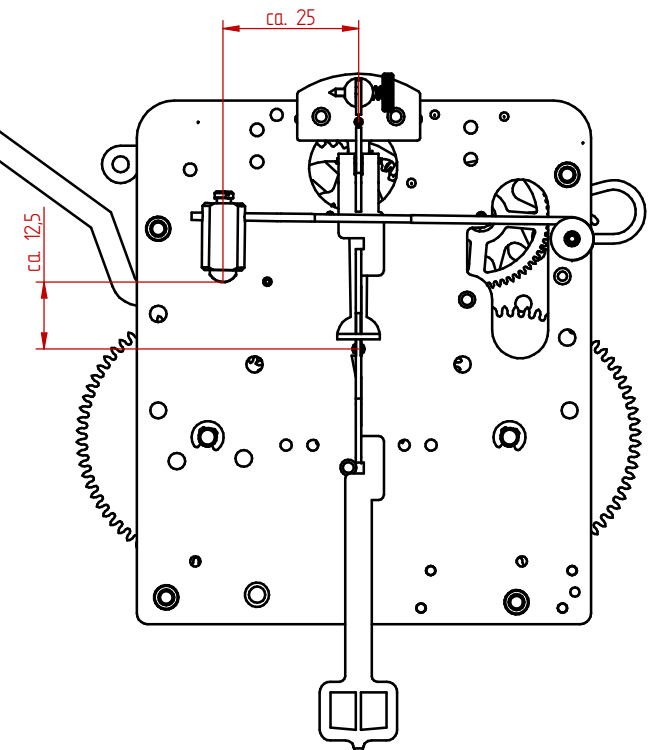

14 Tage Halbstunden Schlagwerk; Federzug; Pendel; Grahamgang; 1 Hammer hinten; Rundgong

14 day movement with 1/2 hour strike; key wound; pendulum; dead beat escapment; 1 hammer behind; coil gong

| | | | | | |
|-----------------------------------------------------------------------------------------------------------------------|----------|-----------------------------------------|----------------------------------|------------------|----------------|
|  <small>78559 Gosheim</small> | | Masse ohne Toleranzangabe DIN 2768 f | Werkstück- kanten DIN 6784 | Maßstab : 1:1 | Gew.: 0,000 kg |
| | | Einbauzeichnung | | | |
| | | Datum | Name | W0141-040 | |
| | | Bear. | 22.03.2019 HMetzger | | |
| | | Gepr. | | | |
| | | Norm | | Blatt 1 von 1 | |
| Zust. | Anderung | Datum | Nam. | | |